



## Luminaire

# Zuli

121-501D-25GGD/830, S



Do you remember the buzzing and flickering lights of your classroom? Fortunately these are long gone. Zuli pendant and surface-mounted LED luminaires ensure comfortable lighting in the classroom, offices and hospitals without these annoyances. These luminaires have direct or direct-indirect emission, with a choice of four lengths and microprism optics, grid and opal diffuser.

## Technical drawing

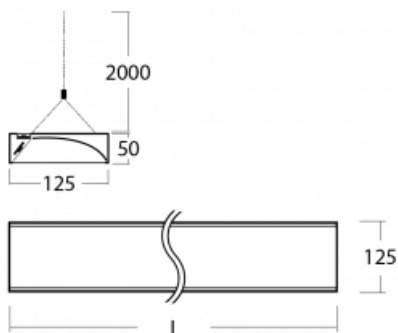

Type of installation	Suspended
Light distribution	Direct-indirect
Luminaire shape	Angular
Colour of the luminaires	Silver
Material	Aluminium
Lifetime	L80/B20 50 000 hours
Warranty	5 years
Description of luminaires	Luminaire suspended
item description	wall washer
Dimensions	1425 mm × 125 mm × 50 mm
Light source	LED MODUL
Type of optical system	Asymmetric reflector
Luminous flux*	7180 lm
Colour Temperature	3000 K warm white
Luminous efficacy	107 lm/W
MacAdam Light source	3
Colour rendering index	80

## Curve

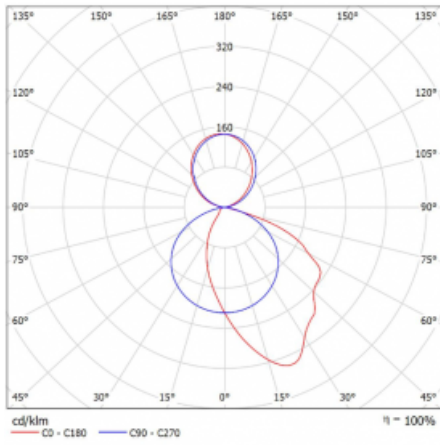

Luminaire power input\* 67.4 W

Connection of the luminaires DALI

Electrical voltage 220-240V

Frequency 50/60Hz

⊕ CE IP 20

\*±10 %

## Downloads

Installation instructions



Photos

